

SUPERJIG - CHAPTER 2

Adjusting the Finger Assembly

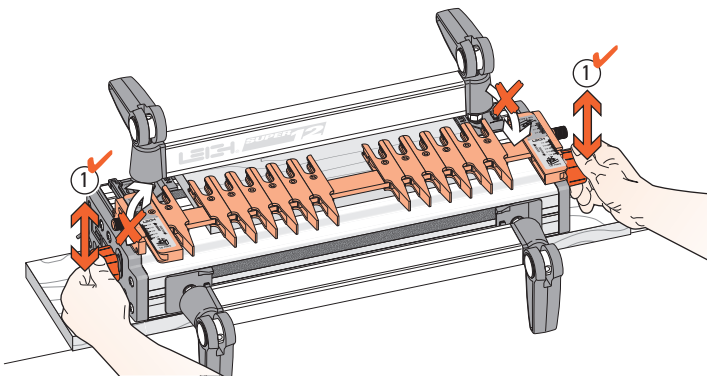

2-1 Practice with the finger assembly height adjustment. Loosen the support bracket knobs and hold them firmly. Raise and lower the assembly evenly, **keeping it level** ①, and tighten the knobs to lock it at various heights. **Do not raise or lower only one end of the finger assembly.**

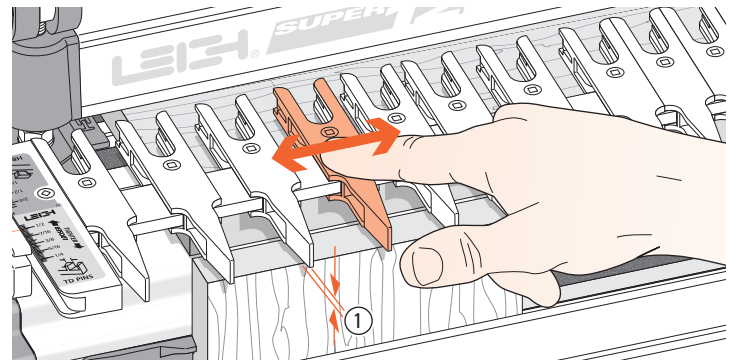

2-2 To practice adjusting the guidefingers, put a board in the front clamp. **Always raise the finger assembly slightly, approximately 1/16" [2mm] above the spacer board and/or workpiece** ①. This is essential to allow the guidefingers to move freely on the guidefinger bar and ensures that the fingers will be level and flush when locked up. Move the guidefingers by pushing on the middle to slide them along the guidefinger bar.

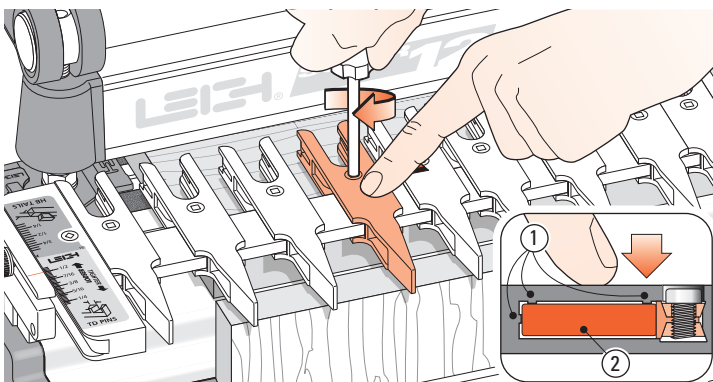

2-3 Loosen about half the guidefingers and practice unlocking, moving, positioning and re-locking them. **Always press on the center of the guidefinger when tightening the screws.** This ensures that the small pads ① on the inside of the finger contact the face of the finger bar ② and keeps all the fingers level.

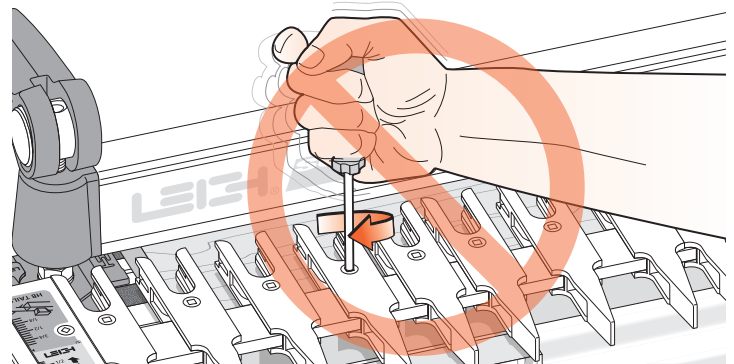

2-4 Do not over-tighten the guidefinger lock screws. The Leigh screwdriver provided will give ample torque for easy lock-up without strain.

Hint: Fingertip tighten a loose screw until the slightest resistance is felt. Do not tighten the screw more than half a turn (180°) from the first contact.

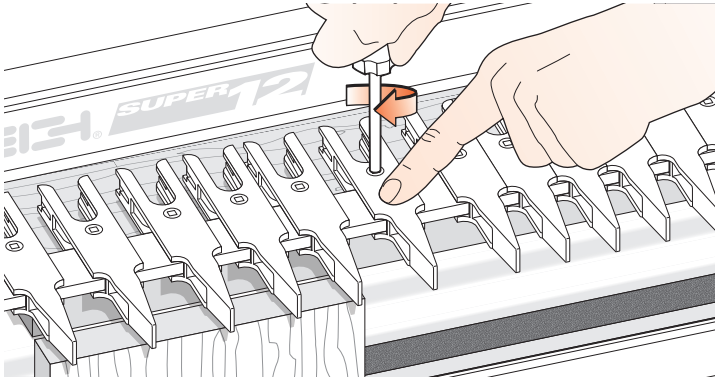

2-5 Always tighten unused guidefingers before routing, as router vibration may cause loose screws and finger lock parts to fall out and be lost.

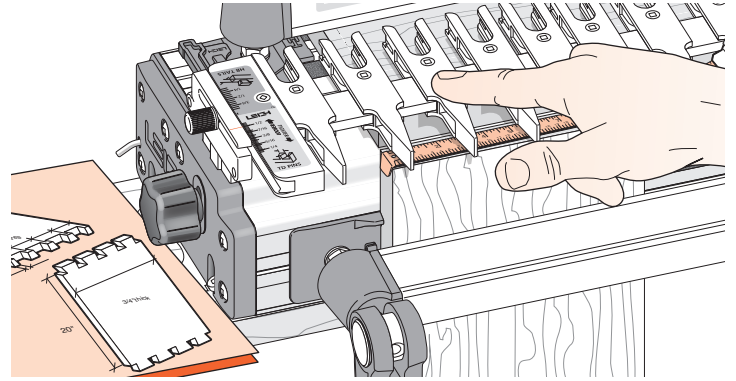

2-6 You can adjust the guidefingers by eye, or by measurement to suit a set of plans. ■