

Rabbeted Half-Blind Dovetails

Before attempting rabbeted half-blind dovetails, first master the techniques of flush half-blind dovetails in Chapter 9, Variably Spaced Half-Blind Dovetails.

Note: Rabbeted half-blind dovetails cannot be routed in a single pass – the lip of a drawer front makes it impractical, as each piece would have to be routed separately, in which case it is easier to use the variably spaced method.

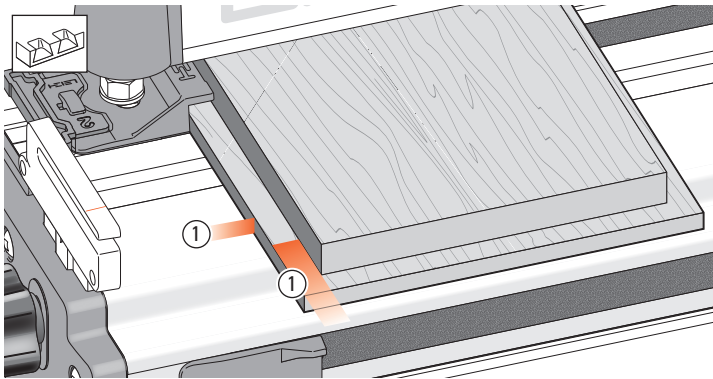

11-1 Provided the drawer front lip is $\frac{3}{8}$ " [9,5mm] or less in each direction ①, you can mount and rout rabbeted drawer fronts and sides exactly the same way as flush drawer fronts, except...

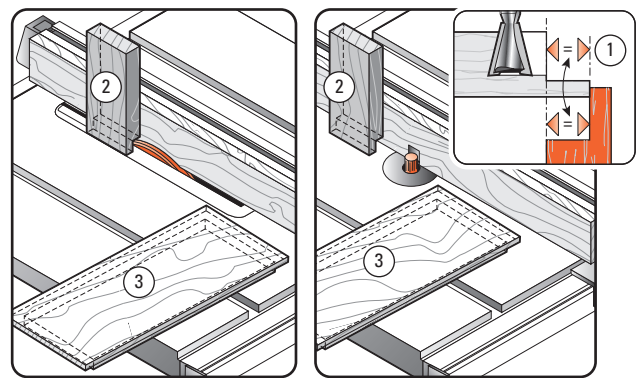

11-2 Rabbeted Pins You will need to block the scrap stop in the front of the jig out from the jig's front face by exactly the width of the rabbet ①.

An easy accurate way to do this is to rabbet the end of the scrap piece ② vertically over a dado blade or router bit at the same time as you rabbet the drawer front (horizontally) ③.

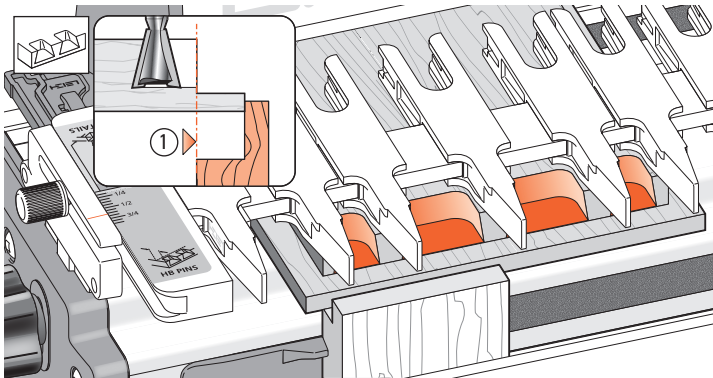

11-3 This brings the pin ends exactly in line with the front jig face ①, ensuring that the scale reading is accurate.

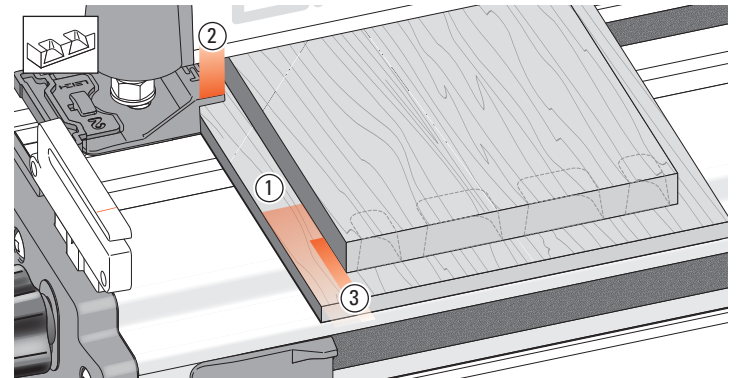

11-4 If the rabbet width ① is greater than the top side stop width of $\frac{3}{8}$ " ②, the drawer side (tailboard) must be blocked away from the front side stop (see 11-5) by exactly the width of the rabbet minus $\frac{3}{8}$ " ③. For example, a $\frac{5}{8}$ " rabbet ① would require the tailboard to be offset by an additional $\frac{1}{4}$ " ③.

Make a spacer block of the required width and...

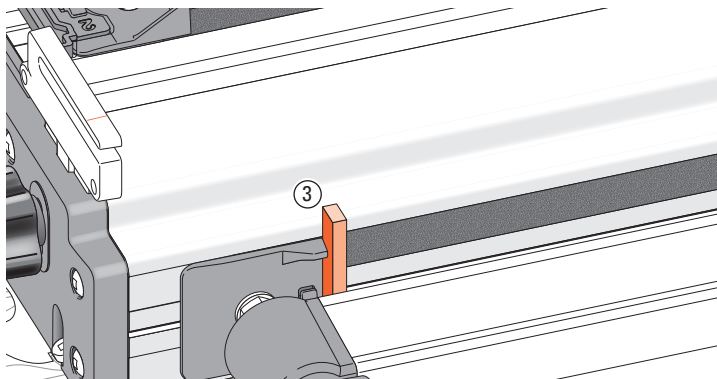

11-5 Stick the block ③ to the jig face with double-sided tape, making sure it touches the side stop.

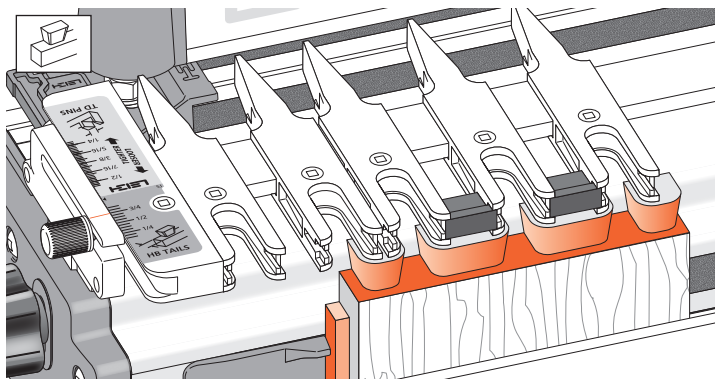

11-6 The drawer side will now be stepped in from the side stop by the width of the rabbet, bringing the sockets in line with the pins.

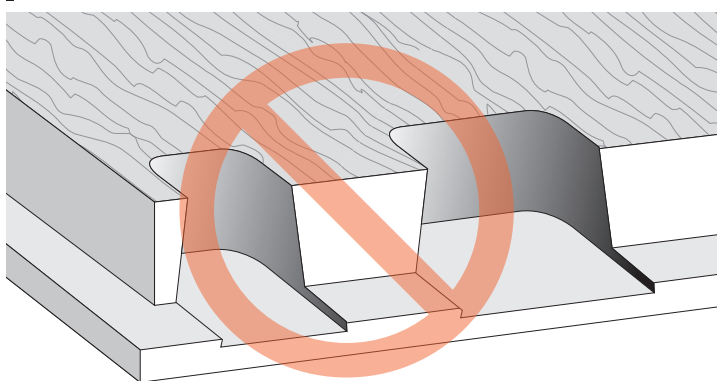

11-7 Make sure you select a dovetail bit that has a working depth of cut less than the rabbet height. Otherwise, you will rout into the rabbet.

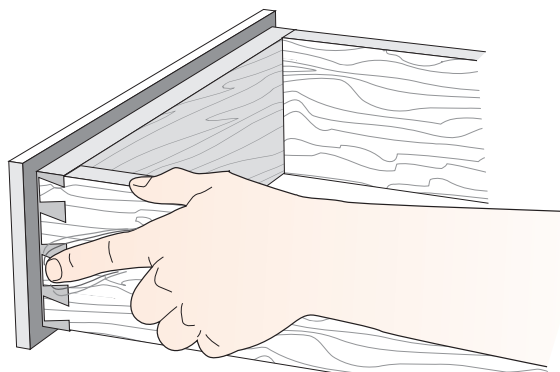

11-8 It is difficult to clean up the drawer sides and front corner after assembling a rabbeted drawer, so make sure the fit is flush before you complete the drawers See 9-28 to 9-30. ■