

## FMT PRO Appendix II Jig Adjustments

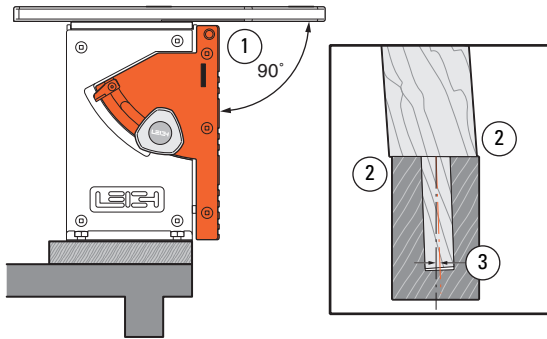

**A2-1 Clamp Plate** The Clamp Plate is factory set square to the table ①. However, this does not guarantee perfectly in-line joints. If your router shaft and bit are not perpendicular to the router sub-base and the Leigh Sub-Base, then the bit will not be square to the Jig Table (nor parallel to the Clamp Plate). This will cause a tiny “step” in the joint alignment ②. This is because the tenon center mark is now offset from the mortise center mark in the assembled joint ③. For clarity, the angle and step in this example is highly exaggerated.

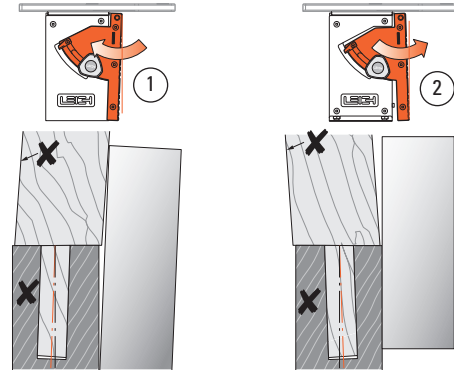

**A2-2** Check your test joints for alignment with a straightedge. The cross represents the inside face toward the clamp face. The left example shows the clamp plate should be adjusted in toward the jig body ①. The right example shows the clamp plate should be adjusted away from the jig body ②. Test and adjust the Clamp Plate angle (see A2-3) until the workpieces are in the same plane, with no joint misalignment.

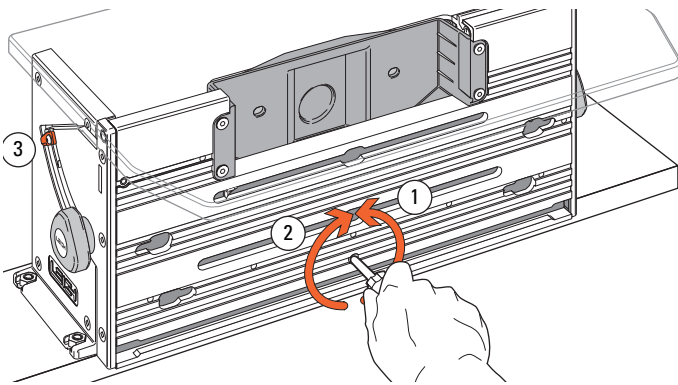

**A2-3** The adjusting screw for setting the clamp plate is in the lower center of the plate. Loosen the quadrant knobs. Use the hex screwdriver to turn the screw counterclockwise to move the plate in ①. Turn the screw clockwise to move the plate out ②. The screw is treated with Loctite™ to prevent accidental rotation. When the clamp plate is square, re-zero the angle indicator if necessary ③.

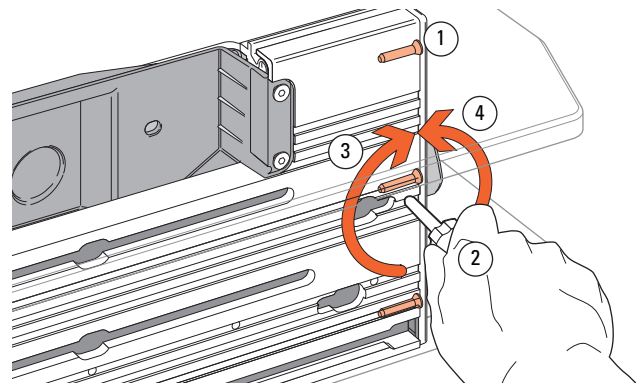

**A2-4 Joint Alignment** The Clamp Plate is precision-set parallel to the table at the factory and should never need attention. However, if it should need adjustment, here's how. First, loosen the two quadrant knobs and tilt the Clamp Plate up approximately 1/4" and re-tighten the knobs. Then slightly loosen the three screws holding the right end quadrant using the square drive screwdriver ①. Use the hex driver to turn the setscrew in this hole ② clockwise to move the right end of the Clamp Plate in toward the jig ③; counterclockwise to move it out ④, then tighten the quadrant screws ①. The adjusting screw is 28 pitch; one turn is 0.036" [9mm]. That's a lot. If adjustment is ever necessary it will likely be a small fraction of a turn.

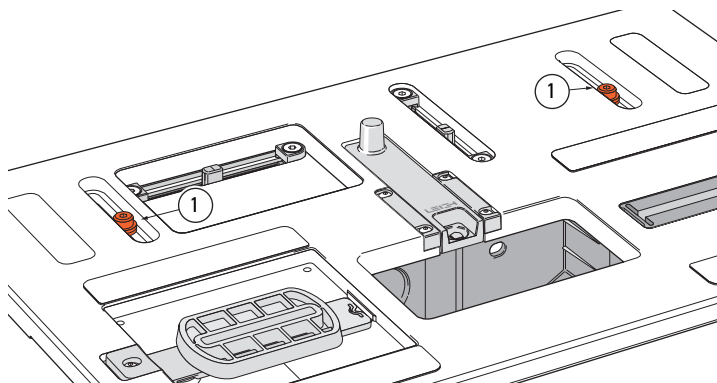

**A2-5 Table Clamp Setting** The setting for this is factory pre-set using a torque tool. Should you need to adjust the pressure, lock the table and lightly tighten the two clamp screws **equally** ①. Do not adjust these screws with the table unlocked. You should be able to work the table lock lever with quite light pressure. When locked, it should not be possible to move the table with firm side to side hand and arm pressure. When unlocked, it should be easy to position the table without sticking. The screws are treated with Loctite™ to prevent accidental rotation.

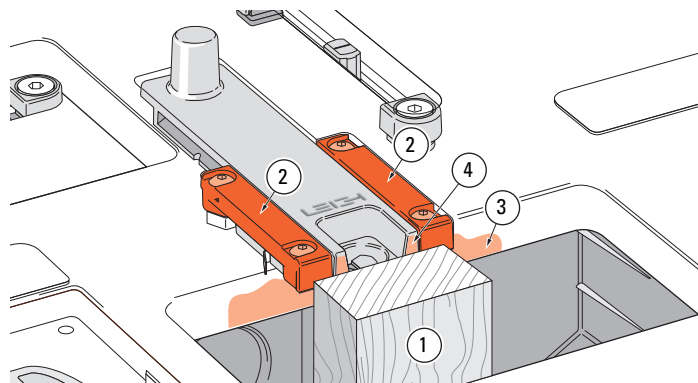

**A2-6 Sight Position** The sight position is factory set. If you ever need to reset it here's how. Clamp a straight vertical rail that projects through the table bit opening ①. Slightly loosen the four small hex cap screws that hold the two sight rails ② using the provided hex key. Move the table forward until the rear edge of the bit opening ③ firmly touches the vertical rail ①, and lock the table. Pull the sight and rails against the wood piece ④; at the same time centring the rear end of the sight in the recess. Tighten the four screws.

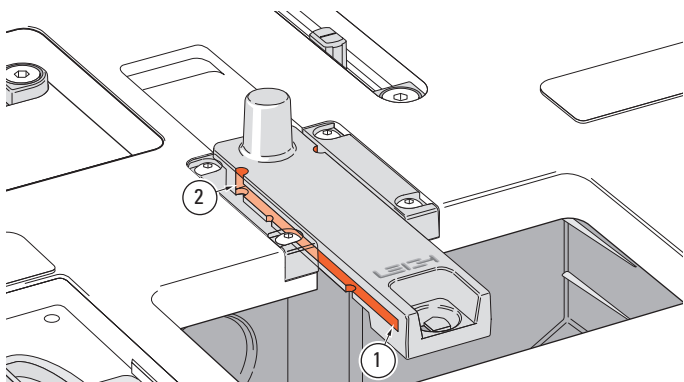

**A2-7 Jig Maintenance** Very little maintenance is required. Fine dust build-up in the front and rear sight stops should be removed from time to time. The end of the small hex key or a piece of wire will do the trick. At the front ① and with the sight to the rear position at ②. Dusting off with compressed air (if available) will keep the jig clean.

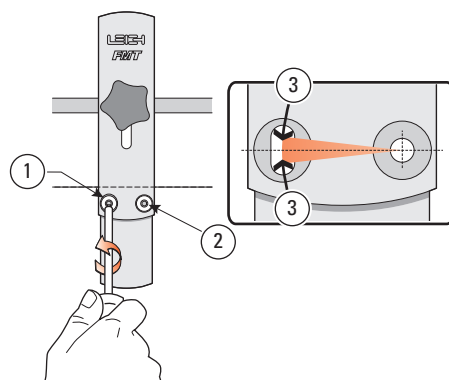

**A2-8** The sidestop fence is squared at the factory, but check your first test joints. If your router/bit is not perfectly perpendicular to the table adjust the sidestop fence: slightly loosen the 'pivot' screw ① and the 'lock' screw ②. Adjust the angle ③ to match the bit and retighten. Rout test joints to confirm correct setting. Once locked in this position it should never need adjusting when used with that same router. ■