

February 2004
 UPDATE

How To Rout Pins at Centres Less Than 1 inch

 These instructions are based on the assumption that you are fully conversant with the dovetailing instructions in the Leigh Jig User Guide. Do not attempt the following procedures until you are.

BLOCKING OVER METHOD

Example:
 A 1 1/2" deep "pencil" drawer

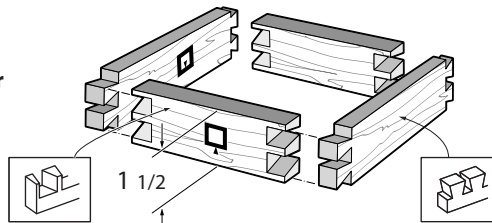

Through Dovetails

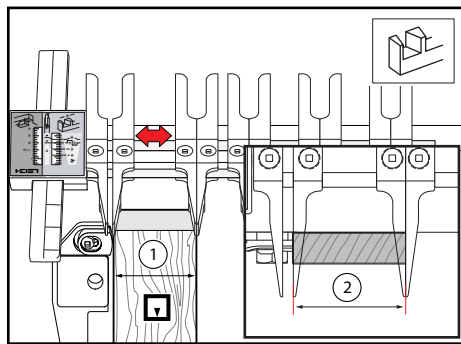

1 e.g. 1/2 thick x 1 1/2" wide boards ^① with a centre pin, using No.70 Dovetail Cutter and a No. 140 straight cutter. Position the guide fingers 1 1/2" apart on centres ^②.

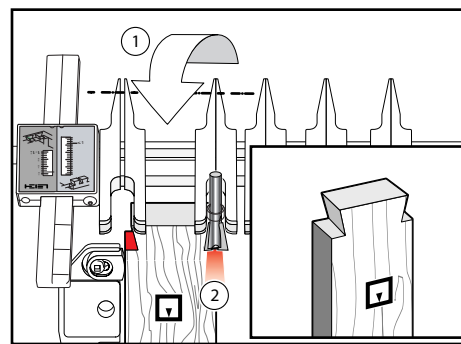

2 Rotate the fingers to Tail mode ^①. Rout the Half pin sockets ^② with the No.70 cutter. Repeat on all ends of the Tail Boards,

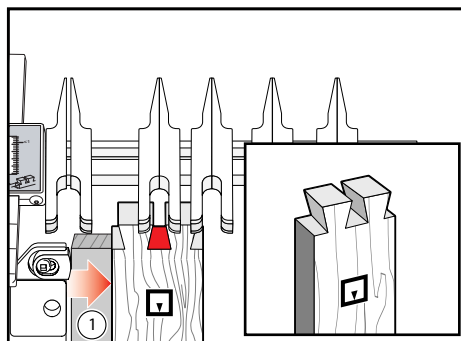

3 Use a 3/4" spacer ^① to block the workpiece away from the side stop. Rout the central socket. Repeat on all ends of the tailboards.

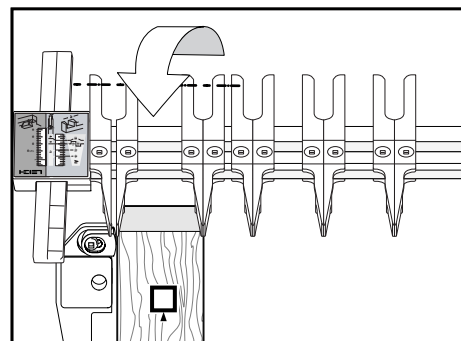

4 Rotate to finger assembly to the TD pin mode.

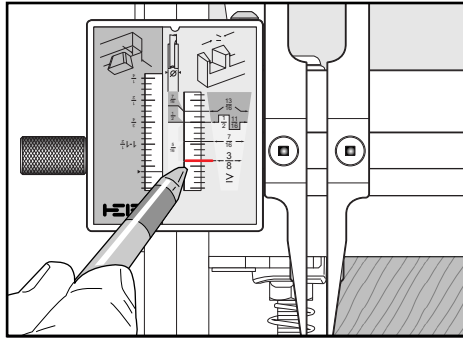

5 Make sure you have already established the correct pin scale setting for joint tightness for the cutter being used. You will have recorded this in your jig user guide.

Note: Your setting may not be as illustrated above.

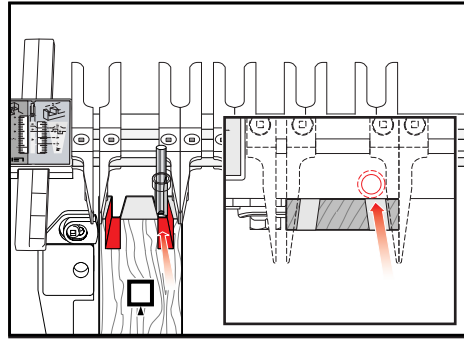

6 Use the No. 140 straight cutter to carefully rout in along each angled pin guide surface and straight out without routing toward the centre pin area. Repeat on all four pin ends.

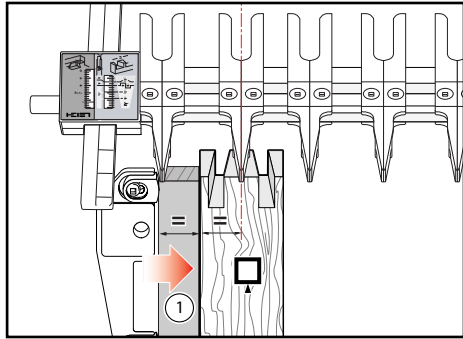

7 Again use the same 3/4" spacer to block the pin pieces away from the side stop ①.

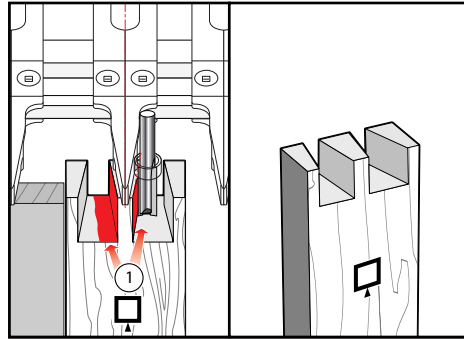

8 Carefully rout either side of centre pin guide ① without routing into the half pins. Repeat on all pin ends.

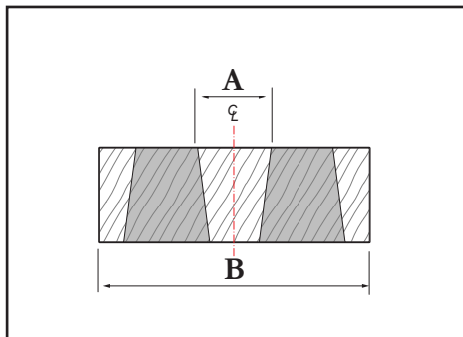

9 Assuming full half pins; the closest theoretical centres possible for the following cutter combinations are:

However, the half pins can be minimized to get slightly narrower board widths.

	A	B
No. 80	1 3/4"	
No. 75	1 5/8"	
No. 70	1 1/2"	
No. 60	1 3/8"	
No. 50	1 1/4"	